

AMMENDMENT TO THE PROPOSAL TO HONOR THE SEVEN LADIES WHO SAVED THE DAVENPORT HOUSE AND BEGAN HISTORIC SAVANNAH FOUNDATION

On behalf of the families of the Seven Ladies who in 1955 saved the Davenport House from demolition and helped to start Historic Savannah Foundation, I am seeking to amend the proposal presented at the June 6th meeting of the Site and Monument Commission per the suggestions offered at that meeting as follows:

1. Place the monument in the center of Columbia Square north of the existing fountain. The monument would be centered at the southern edge of the existing planting, centered behind the two existing benches.
2. There would be no additional bench placed in the square to accompany the monument.



The monument would be placed approximately where the white sign now sits.

We have met with representatives from the Park and Tree Commission, and they are supportive of this proposed change.

Thank you for your consideration of this amended proposal.

Lucy Brannen and Catharine Varndoe for the families.

PROJECT DESCRIPTION FOR PROPOSED MONUMENT

HONORING THE SEVEN LADIES WHO SAVED THE DAVENPORT HOUSE AND WERE THE CATALYST FOR THE ESTABLISHMENT OF HISTORIC SAVANNAH FOUNDATION

SUBMITTED BY MEMBERS OF THEIR FAMILIES

May 2, 2024

In the 1950's, Savannah, GA, found itself at a crossroads. Economic stresses from almost fifty years of decline and southside migration of families and businesses were forcing businesses and individuals to set aside long-held respect and concern for the buildings, squares and city plan that formed the heart of downtown Savannah. These homes, businesses and public spaces were essential ingredients in the carefully laid out city plan envisioned and begun under General James Oglethorpe when he founded Savannah in 1733. Yet they were increasingly being demolished to provide space for more profitable ventures. In 1954, the Old City Market, which had been built on the site of previous city markets was torn down to make way for a parking garage. The following year a local funeral home needed a parking lot and planned to provide the required space by tearing down the 1820 Davenport House, a stellar example of Federal architecture. Local residents Anna Hunter and Lucy McIntire gathered five ladies together to stop this from happening. This group of seven ladies: Katherine Judkins Clark, Elinor Adler Dillard, Anna Colquitt Hunter, Lucy Barrow McIntire, Dorothy Ripley Roebing, Nola McEvoy Roos, and Jane Adair Wright, worked tirelessly to rally support and raise the necessary \$22,500 to purchase the building and save it from demolition. They immediately saw the need for a permanent organization with the mission to save every possible historic building in the city and with a group of other like-minded citizens began Historic Savannah Foundation for this purpose. In the past almost 70 years, over 400+ endangered structures have been preserved. This has resulted in the preservation of over 1000 buildings and spaces that form the current Historic District which span the previous 291 years of Savannah's existence.

Today many local citizens are not aware of this history. As we approach the 70th anniversary of the founding of the Historic Savannah movement in 2025, it is time to tell this story in a permanent way that also honors these seven ladies for their courage and foresight in preserving this history for generations to come. To that end, it is proposed that:

A monument and bench be erected in Columbia Square to honor these Seven Ladies and their contributions especially those of the summer of 1955.

The monument will be located in the northwestern quadrant of Columbia Square directly across from the Davenport House. That area is partly paved with bricks with the remaining portion covered in grass surrounded by a low fence. It is the site/stopping point for tours including that offered by the Davenport House. It is also across from a pick-up point for tour buses so the addition of a bench in this shady area would allow a convenient seat for tourists as they participate in the tours or await pick-up, especially those who have difficulty standing for lengthy periods of time. The monument would be placed at the southern end of the existing bricked area and surrounded by a small number of additional bricks so that

it would be incorporated into the existing landscaping. The existing fence would be relocated at the rear of the monument. There is an existing historical marker on the location which makes no mention of the Seven Women and their contribution.

The monument would be constructed of grey granite with a slanted front resting on a base of grey granite. On the slanted portion of the monument will be two bronze plaques. The top plaque will contain silhouettes of the heads of the seven ladies in *bas relief*. The lower plaque will contain the names of the women and a brief description of their accomplishments. DePue Monument Company of Savannah, GA, has assisted with the design of the monument and will be installing the monument on site. The monument was inspired by the Liberty Ship Monument located on River Street for which a picture is provided. The brick work and adjusting the existing fence will be contracted through the Park and Tree Commission and paid for by this group. The funds for this project are being raised by the families of the seven women who are contributors along with other interested parties. Historic Savannah Foundation is assisting with advice and by processing of the funds raised. An estimated budget of \$35,000 has been established to cover the anticipated costs of this project. A time frame of approximately 14 months is anticipated to complete this project.

As to the twelve themes addressed by the application, this commemoration would embody all of them due to the far reaching and pervasive impact of the actions and influence of Seven Ladies and Historic Savannah in the Savannah/Chatham County area. Their work and preservation efforts have preserved the homes, neighborhoods and stories of all elements of the Savannah/Chatham County community by laying groundwork for the expansion of the original Historic District, preserving and inspiring the restoration of the waterfront area on both sides of the Savannah River, other areas of the county and providing the framework for future projects throughout the district. The guidelines developed have preserved the integrity of the historic area through almost seventy (70) years of development and have significantly impacted historical, educational, financial, maritime, scientific and engineering institutions, and commercial aspects of the area through a major influx of tourists and industries drawn by the beauty, spectacular architecture and ambience of the neighborhoods of Savannah. Venues have been restored and developed to highlight the stories of the many citizens who contributed to the life and livelihood of every segment of our community and its cultural and ethnic heritage. Numerous works of art, volumes of literature, dramas, movies, television productions and educational materials have been created to tell the story of the almost 300 years of existence of Savannah, its culture and citizens. The warmth and strong character of the community, the Hostess City of the South, is a continuing reflection of the strong character and love for their home exemplified by the actions of these Seven Ladies.

In light of this enduring impact, it is our sincere desire that the contribution of these Seven Ladies be preserved and honored in a public space to heighten the awareness of their work and enhance the knowledge and impact of their legacy for generations to come.

Respectfully submitted on behalf of the families of the Seven Ladies,

Lucy S. Brannen

Catharine E. Varnedoe

Additional Attachments

| | |
|---------|---|
| Page 4 | Picture of the Seven Ladies |
| Page 5 | Artist Rendering of Monument and Bench Installed |
| Page 6 | Photographs of the Proposed Site |
| Page 7 | Map Showing Location of Proposed Monument and Bench |
| Page 8 | Proposed Location of Monument and Bench on Site |
| Page 9 | Monument Specifications |
| Page 10 | Bronze Plaques with Proposed Wording |
| Page 11 | Specs for Monument and Bench -1 |
| Page 12 | Specs for Monument and Bench – 2 |
| Page 13 | Picture of Liberty Ship Monument on River Street |

Proudly Presenting Our Heroines

These valiant ladies had the
keen foresight to halt demolition of
architectural treasures.







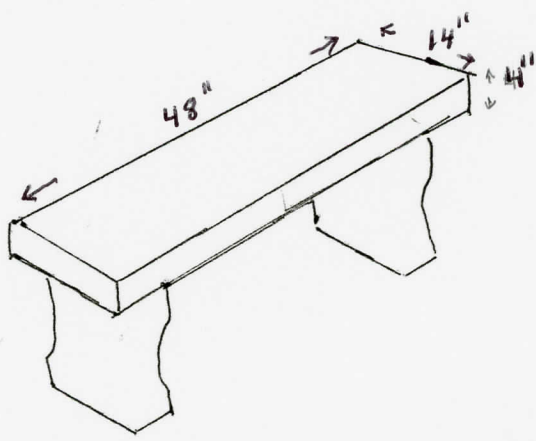
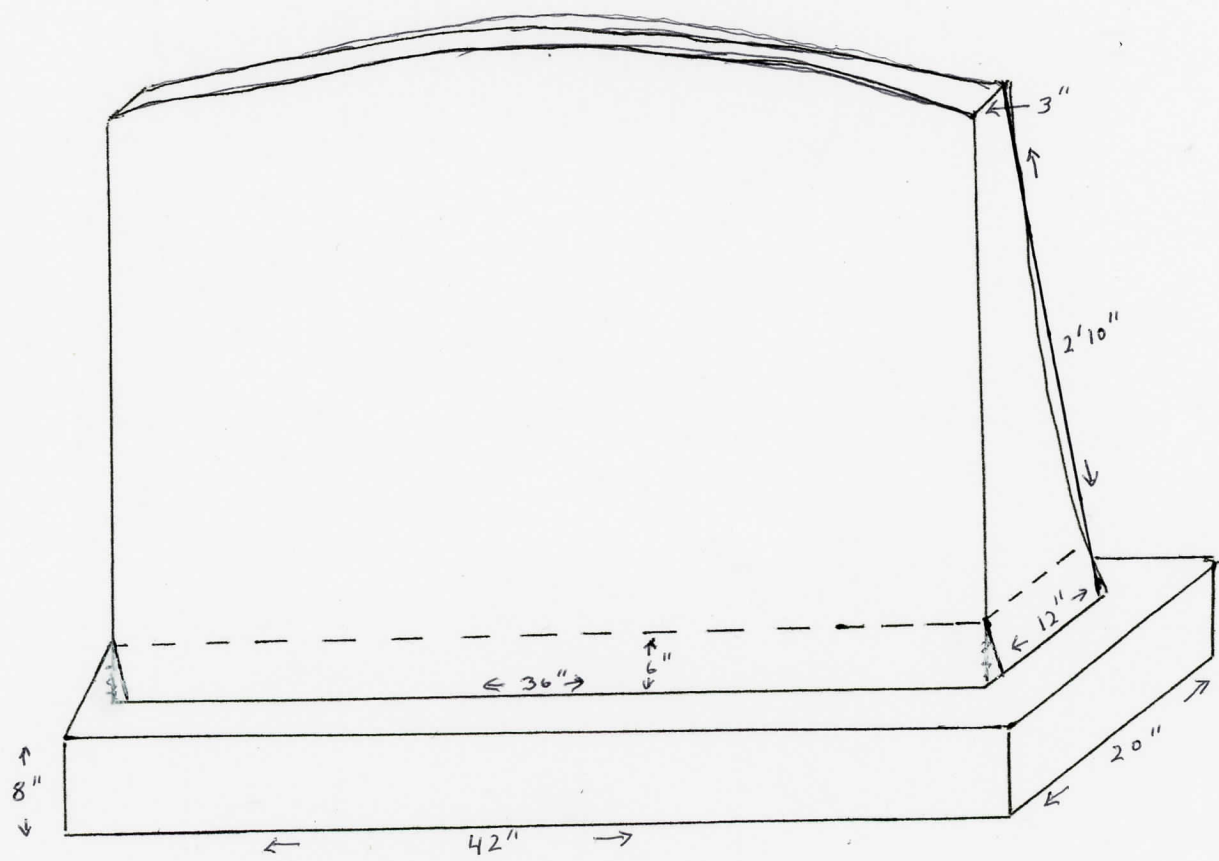



30 X 7

**KATHERINE JUDKINS CLARK—ELINOR ADLER DILLARD—ANNA CLOQUITT HUNTER
LUCY BARROW McINTIRE—DOROTHY RIPLEY ROEBLING
NOLA McEVOY ROOS—JANE ADAIR WRIGHT**

These seven ladies are recognized and honored in grateful recognition and lasting appreciation of their heroic effort in 1955 to save the Davenport House from demolition and to inspire the preservation of historic structures in the city of Savannah. Their success in raising the necessary funds to purchase the house provided the catalyst to found Historic Savannah Foundation with a group of like-minded Savannah residents. This proved to be the turning point to limit destruction of the remaining historic structures in the city and to establish basic guidelines for future preservation efforts.

30 X 15

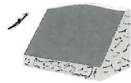

SLANT MARKER
3-0 X 1-0 X 2-10

BRONZE PLAQUE 30 X 20

GRANITE BENCH
4-0 X 1-2 X 0-4

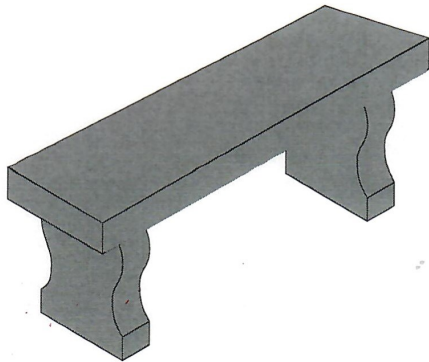

3-8 X 1-8 X 0-8
POL. TOP, BRP

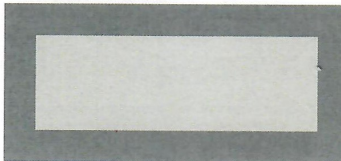

3" TOP NOSING

POL. FACE

BACK SAWN

6" FRONT NOSING



SLANT MARKER

3-0 X 1-0 X 2-10

BRONZE PLAQUE 30 X 20



3-8 X 1-8 X 0-8

POL. TOP, BRP



3" TOP NOSING

POL. FACE

BACK SAWN

6" FRONT NOSING

