



## HISTORIC SITE AND MONUMENT COMMISSION (HSMC)

Application for Historical Markers, Monuments, and Public Art

HSMC reviews all historical markers, monuments, and public art on public property and all markers visible from the public right-of-way on private property within all local historic districts. Applications must be complete before the HSMC can begin the review process. Submit this application form and all supplemental documentation as required in the "Instructions: Submittal Criteria Checklist" with one hard copy and in PDF electronic format. Electronic files can be emailed (10mb limit) or submitted with the application on a disc.

File No.: \_\_\_\_\_ (staff only)

### Applicant Contact Information:

Name: Georgia Historical Society

Address: 104 West Gaston Street

City: Savannah State GA Zip 31401

Phone: 912.651.2125 ext. 119 E-Mail Address enb0720@gmail.com

### Property Owner Contact Information and Consent (Complete only if the marker will be on private property):

Name: Andrew Berrien Jones

Address: 666 Greenwich Street #801

City: New York State NY Zip 10014

Phone: 646-248-2050 E-Mail Address andrewjonesnyc@aol.com

Official Correspondence:  Applicant  Owner  Other \_\_\_\_\_ (Check all that apply)

### Property Information for Proposed Marker: (PIN information can be found at [www.sagis.org](http://www.sagis.org).)

Public Property  Private Property PIN (Property Identification Number): 2-0004-41-003

Address: 322-324 E Broughton Street, Savannah, GA 31401

### Scope of Work: (Check all that apply.)

HISTORICAL MARKER:	MONUMENT:
<input type="checkbox"/> Freestanding	<input type="checkbox"/> Person
<input checked="" type="checkbox"/> Wall-Mounted	<input type="checkbox"/> Place
<input type="checkbox"/> Ground-Embedded	<input type="checkbox"/> Event
<input type="checkbox"/> Other	<input type="checkbox"/> Other
PUBLIC ART (commissioned or existing work):	
<input type="checkbox"/> Mural	
<input type="checkbox"/> Sculpture	
<input type="checkbox"/> Other	

**Project Description:** Describe the proposed project and scope of work in detail. Additional pages may be attached. Submit all supplemental documentation as required in the separate "Instructions: Submittal Criteria Checklist."

Please see attached documentation.

Questions: Email the Preservation Department at [historic@thempc.org](mailto:historic@thempc.org) or call 912-651-1440.

Email, Hand Deliver or Mail Applications: MPC, Historic Preservation Department, 110 East State Street, Savannah, GA 31401

**2017 Savannah-Chatham County Historic Site and Monument Commission Meeting Schedule:**

<b>Application Deadline (Due by Close of Business: 5pm)</b>	<b>Meeting Date</b>
<input type="checkbox"/> December 12, 2016	January 5, 2017
<input checked="" type="checkbox"/> January 9, 2017	February 2, 2017
<input type="checkbox"/> February 6, 2017	March 2, 2017
<input type="checkbox"/> March 13, 2017	April 6, 2017
<input type="checkbox"/> April 10, 2017	May 4, 2017
<input type="checkbox"/> May 15, 2017	June 1, 2017
<input type="checkbox"/> June 12, 2017	July 6, 2017
<input type="checkbox"/> July 10, 2017	August 3, 2017
<input type="checkbox"/> August 14, 2017	September 7, 2017
<input type="checkbox"/> September 12, 2017	October 5, 2017
<input type="checkbox"/> October 16, 2017	November 2, 2017
<input type="checkbox"/> November 13, 2017	December 7, 2017

**Estimated Cost of the Proposed Work:** \$ 5,000.00

**Filing Fee Schedule:**

No filing fee is required for HSMC review.

**Public Notice for Historic Site and Monument Commission Meetings:**

The applicant is responsible for posting the Board Meeting signs provided by the MPC fifteen (15) days prior to the HSMC Meeting. Refer to *Chapter 9 of the Markers, Monuments, and Public Art Master Plan and Guidelines for the City of Savannah* for additional posting requirements.

**Signature of Legal Owner or Authorized Agent:**

I have read and understand all the information enclosed in this application form. I understand that an Escrow Payment is required for any historical marker erected on public property. I hereby certify that I am the legal owner or authorized agent for the legal owner of the subject property.

**Signature:** Elise Butler

**Date:** 01/05/17

Questions: Email the Preservation Department at [historic@thempc.org](mailto:historic@thempc.org) or call 912-651-1440.

Email, Hand Deliver or Mail Applications: MPC, Historic Preservation Department, 110 East State Street, Savannah, GA 31401

## **A: Project Description**

The Georgia Historical Society (GHS) in partnership with the National Society Colonial Dames XVII, Adam Brinson I, Georgia chapter will erect a new historical marker at the site of the Berrien House (322-324 E. Broughton Street). The historical marker text (see Supplement E) relates the history of the house's inhabitants, focusing on Major John Berrien and John Macpherson Berrien. The historical marker is to be mounted by David Kelley of Historic Preservation Consulting on the façade of the building facing Broughton Street.

**B: Photographs and Maps**

**Option I along Broughton Street**







Option 2 along Habersham Street





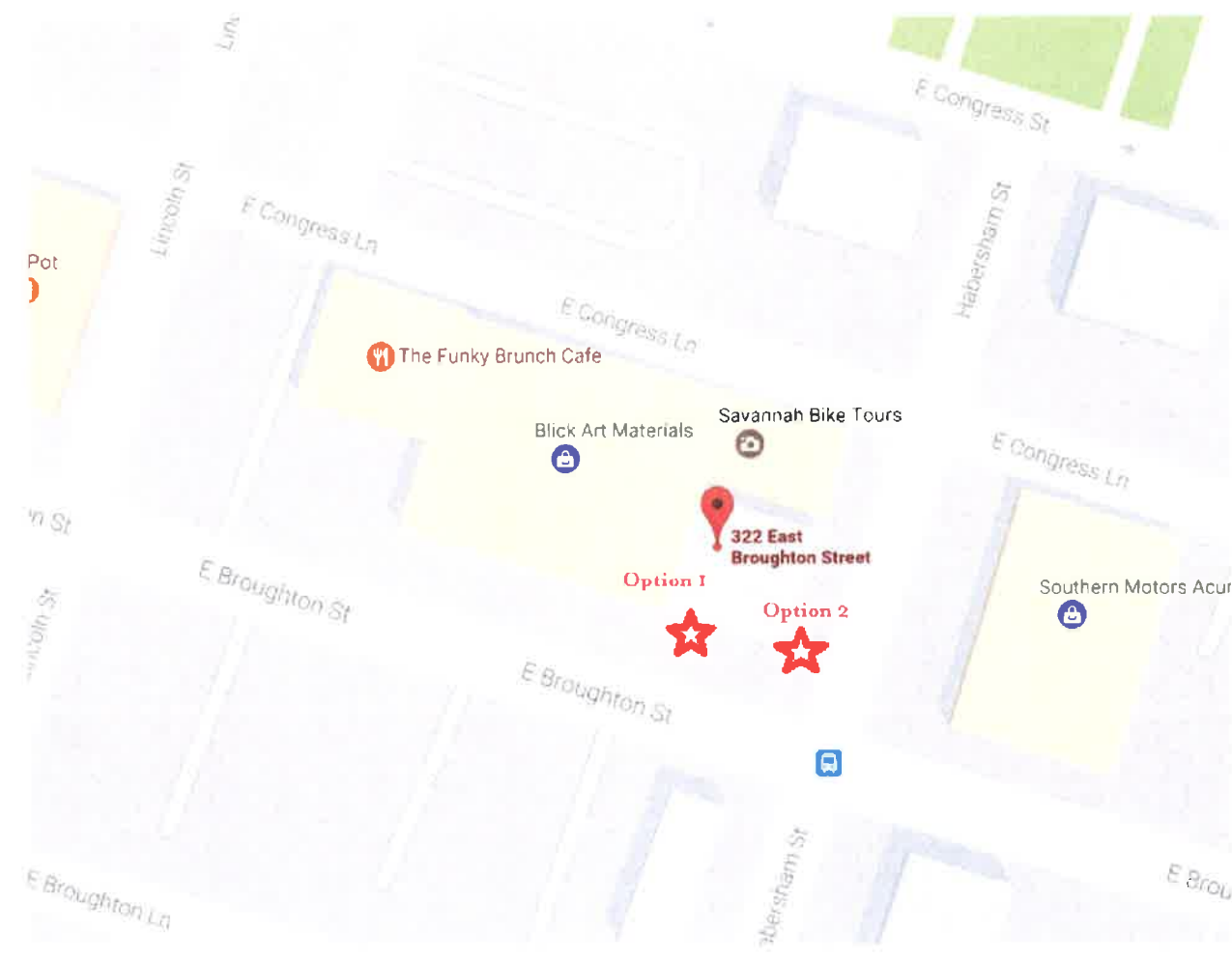

Pot

The Funky Brunch Cafe

Blick Art Materials

Savannah Bike Tours

322 East Broughton Street

Option 1

Option 2

Southern Motors Acura



## **C: Themes**

The Berrien House historical marker demonstrates the themes of “Arts and Humanities,” “Civic and Institutional,” “Industry and Commerce,” “Military History,” and “Local History.”

### **Arts and Humanities**

The Berrien House historical marker demonstrates the Arts and Humanities theme through John Macpherson Berrien’s professional and cultural accomplishments. Often referred to as “America’s Cicero” due to his skill as an orator, Berrien was the first president and one of the founders of the Georgia Historical Society in 1839. As a founder, Berrien helped establish the oldest continuously operating historical society in the South.

### **Civic and Institutional**

The Berrien House historical marker demonstrates the Civic and Institutional theme through the accomplishments of Major John Berrien and John Macpherson Berrien. Major Berrien, a veteran of the Revolutionary War, served as the Collector of Customs under the Confederation government and state treasurer. Later he was appointed the Inspector of Revenue of the Port of Savannah by President George Washington. John Macpherson Berrien also led an active political life. Berrien served as judge, United States senator, and U.S. Attorney General. In 1844, the Berrien family hosted presidential candidate Henry Clay at their residence.

### **Industry and Commerce**

Major John Berrien’s role as Inspector of Revenue of the Port of Savannah illustrates Berrien’s importance in the industry and commerce of the City of Savannah, the State of Georgia, and the early American Republic. As Inspector of Revenue, Berrien oversaw the inspection and collection of duties on ships and their cargo as they entered the Port of Savannah.

### **Military History**

Major John Berrien’s service to the Continental Army illustrates the theme of Military History. During the Revolutionary War, Berrien served at Valley Forge and fought in the Battle of Monmouth.

### **Local History**

As referenced above, the Berrien House historical marker demonstrates both Major Berrien and John Macpherson Berrien’s impact on the City of Savannah. The Berrien Family’s contributions by holding multiple public offices at the local, state, and national level, as well as John Macpherson Berrien’s involvement in the founding of the Georgia Historical Society illustrate the family’s lasting impact on the city and state. With the recent exterior renovation of the Berrien House, the placement of a historical marker ensures that the family’s history and impact on the city is accessible to visitors and residents alike for years to come.

D: Marker Drawing

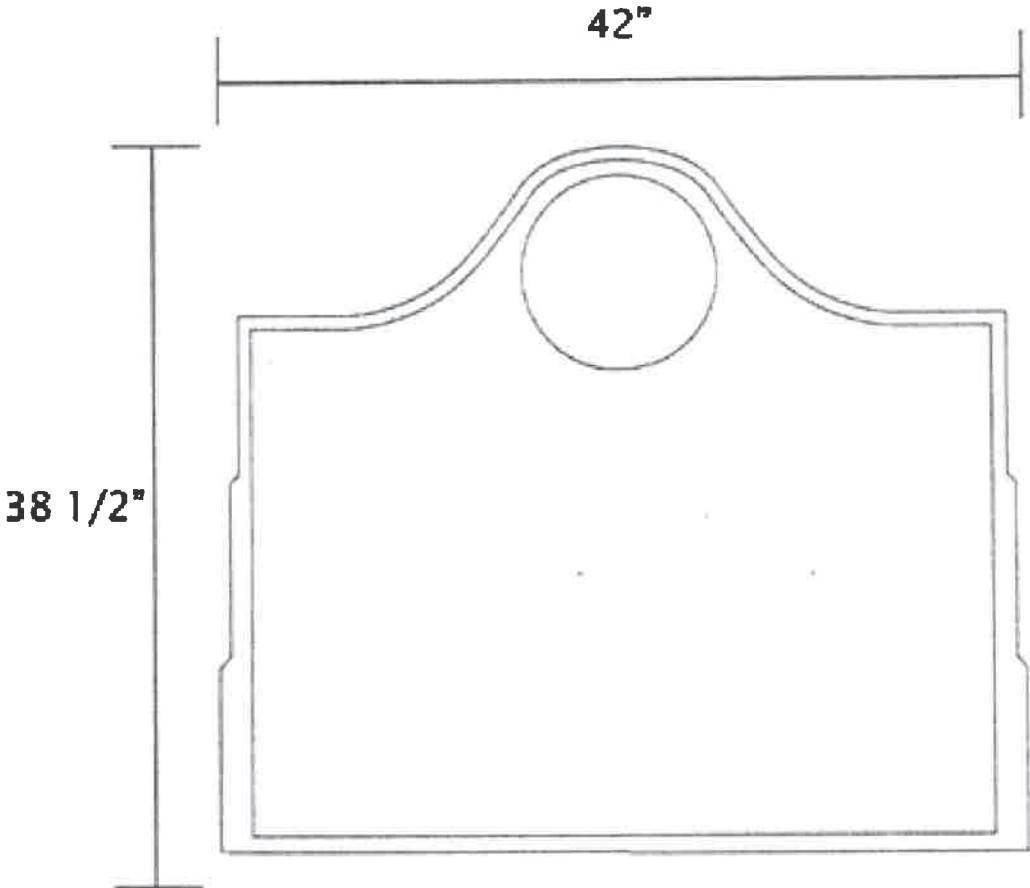

## E. Historical Marker Text

### The Berrien House, ca. 1791

Major John Berrien (1759-1815) was a Revolutionary War officer who served at Valley Forge and fought at the Battle of Monmouth. Berrien, a New Jersey native who moved to Georgia in 1775, was an original member of the Society of the Cincinnati in the State of Georgia. President George Washington appointed Berrien as Inspector of Revenue of the Port of Savannah in 1792. Berrien, who lived at this site, also served as alderman and state treasurer. His son, John Macpherson Berrien, "America's Cicero," lived here from 1822 until his death in 1856, having served as a US senator, Attorney General under Andrew Jackson, and first president of the Georgia Historical Society. Political ally Henry Clay stayed here during his 1844 presidential campaign. Andrew Berrien Jones, a descendant, began the restoration of the house in 2012.

Erected by the Georgia Historical Society and National Society Colonial Dames XVII Century,  
Adam Brinson I, Georgia

#### **F. Marker Installation**

The historical marker will be installed by Historic Preservation Consulting using masonry-appropriate fasteners to the façade of the Berrien House.

#### **G. Estimate of Costs**

The estimated overall cost for a historical marker within the Georgia Historical Marker Program is \$5000.00.

#### **H. Funds Secured**

The Georgia Historical Society has secured funds of \$5000.00 for the total cost of the historical marker.

#### **I. Escrow Payment**

The Georgia Historical Society, as administrators of the Georgia Historical Marker Program along with the sponsoring organization(s) listed in the accompanying Sponsor Agreement Form, take responsibility for the repair and replacement of the submitted historical marker. We therefore ask that the Escrow Payment mentioned in the MPC Historical Marker Application be waved.

Please contact the Georgia Historical Society with any questions or concerns about the ongoing maintenance of this proposed historical marker.

#### **J. Letter of Consent**

Please find the enclosed Property Owner Agreement.



Property Owner Marker Easement/Agreement

As the owner of the property at 322 EAST BROUGHTON ST. SAVANNAH, GA 31901 address of property

I/We agree to allow the erection of said historical marker for/on this property.

I/We have been notified by the Georgia Historical Society as to the subject of/proposed site for said marker and agree that this is acceptable. It is understood that the marker will not be moved, removed, or altered in any way without prior consent from both the Georgia Historical Society and the marker sponsor(s).

Form with fields for sponsoring organization, sponsor telephone, sponsor mailing address, city, state, zip code.

I/We understand that the historical marker is being erected for the purpose of sharing Georgia history with the general public and agree to make fully accessible said marker.

I/We understand that it is the responsibility of the sponsor(s) to maintain and repaint said marker, and to notify the Georgia Historical Society in the event of damage, vandalism or loss. If the marker requires maintenance, the property owner may contact either the sponsor(s) or the Georgia Historical Society at (912)857-2723.

I/We understand that upon the sale or transfer of said property, this agreement shall also be transferred and honored as a binding easement for the said marker and that it is the seller's responsibility to inform the buyer of this easement.

Form with fields for title of marker, county in which erected, name of property owner, mailing address, telephone, city, state, zip code, date, and signature of property owner.