



HISTORIC SITE AND MONUMENT COMMISSION (HSMC)

Application for Historical Markers, Monuments, and Public Art

HSMC reviews all historical markers, monuments, and public art on public property; markers, monuments, and public art visible from the public right-of-way on private property within all local historic districts; murals visible from the public right-of-way.

Applications that do not provide documentation or required materials will be noted as incomplete and may result in delays in the Commission or Staff's review of the application and/or denial of the request. Revisions made to the applications after the submittal deadline

and prior to the Commission hearing may be continued to the following month's hearing. The Commission reserves the right to require additional information if it believes that the submission of such information is necessary to understand the nature of the intended activity.

Submissions will only be accepted when emailed to historic@thempc.org. Ensure the file size does not exceed 10 MB.

For questions, email preservationquestions@thempc.org or call 912-651-1440.

Do not email questions to historic@thempc.org. If email is not available, contact the office for alternate arrangements.

File No.: _____ (staff only)

Applicant Contact Information:

Name: _____

Address: _____

City: _____ State _____ Zip _____

Phone: _____ E-Mail Address _____

Property Owner Contact Information and Consent (Complete only if the marker will be on private property):

Name: _____

Address: _____

City: _____ State _____ Zip _____

Phone: _____ E-Mail Address _____

Official Correspondence: Applicant Owner Other _____ (Check all that apply)

Property Information: (PIN information can be found at www.sagis.org.)

Public Property Private Property PIN (Property Identification Number): _____

Address: _____

Scope of Work: (Check all that apply.)

HISTORICAL MARKER:	MONUMENT:
<input type="checkbox"/> Freestanding	<input type="checkbox"/> Person
<input type="checkbox"/> Wall-Mounted	<input type="checkbox"/> Place
<input type="checkbox"/> Ground-Embedded	<input type="checkbox"/> Event
<input type="checkbox"/> Other:	<input type="checkbox"/> Other:
PUBLIC ART / MURAL (Commissioned or Existing Work):	NAMING AND RENAMING:
<input type="checkbox"/> Mural	<input type="checkbox"/> Public Property
<input type="checkbox"/> Sculpture	<input type="checkbox"/> Public Facilities
<input type="checkbox"/> Other:	<input type="checkbox"/> Public Streets

Project Description: Describe the proposed project and scope of work in detail. Additional pages may be attached. Submit all supplemental documentation as required in the separate “Instructions: Submittal Criteria Checklist.”

2023 Pre-Application Conference Schedule:

First and Fourth Tuesdays of the Month	9am, 9:45am, 10:30am, 11:15am, 11:45am
First and Fourth Thursdays of the Month	1pm, 1:45pm, 2:30pm, 3:14pm, 4:30pm

2023 Savannah-Chatham County Historic Site and Monument Commission Meeting Schedule:

Application Deadline (Due by Close of Business: 5pm)	Meeting Date
<input type="checkbox"/> Thursday, December 1, 2022	Thursday, January 5, 2023
<input type="checkbox"/> January 5	February 2
<input type="checkbox"/> February 2	March 2
<input type="checkbox"/> March 2	April 6
<input type="checkbox"/> April 6	May 4
<input type="checkbox"/> May 4	June 1
<input type="checkbox"/> June 1	July 13
<input type="checkbox"/> July 13	August 3
<input type="checkbox"/> August 3	September 7
<input type="checkbox"/> September 7	October 5
<input type="checkbox"/> October 5	November 2
<input type="checkbox"/> November 2	December 14

Estimated Cost of the Proposed Work: \$ _____

Filing Fee Schedule:

No filing fee is required for HSMC review.

Public Notice for Historic Site and Monument Commission Meetings:

The applicant is responsible for posting the Board Meeting signs provided by the MPC fifteen (15) days prior to the HSMC Meeting. Refer to *Chapter 9 of the Markers, Monuments, and Public Art Master Plan and Guidelines for the City of Savannah* for additional posting requirements.

Signature of Legal Owner or Authorized Agent:

I have read and understand all the information enclosed in this application form. I understand that an Escrow Payment is required for any historical marker erected on public property. I hereby certify that I am the legal owner or authorized agent for the legal owner of the subject property.

Signature: _____ **Date:** _____

Submissions will only be accepted when emailed to historic@thempc.org. Ensure the file size does not exceed 10 MB. Please do not submit questions to historic@thempc.org. For questions, email preservationquestions@thempc.org or call 912-651-1440. Please do not submit applications to preservationquestions@thempc.org. If email is not available, contact the office for alternate arrangements

A complete application submission consists of:

1. Complete, signed application
2. Complete, signed checklist(s) for each request
3. Checklist documentation
4. Payment receipt

Applications that do not provide documentation or required materials will be noted as incomplete and may result in delays in the Commission or Staff’s review of the application and/or denial of the request

Project Description:

Installation of a granite ground marker to identify/commemorate the history of this public square, including its establishment, former name, and new name.

Themes:

- Civic and Institutional: marker provides a record of the City of Savannah's actions regarding this public space.
- Local History: marker commemorates the history of this public space.

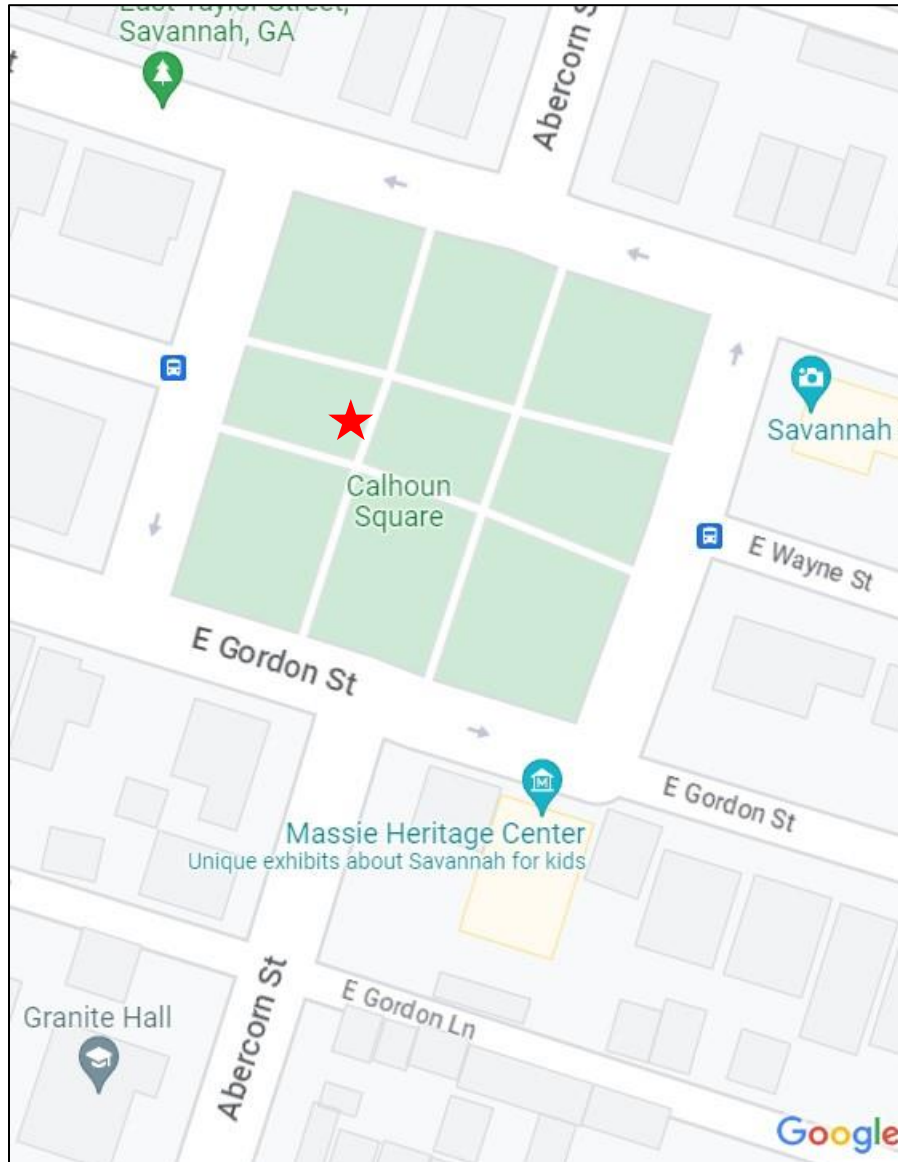
Location Map:

Location: Public square at the intersection of Abercorn and East Wayne streets, in the landscaped bed on the west center adjacent to the western North-South sidewalk through the square.

Location as seen from the walkways:



Proposed Design:

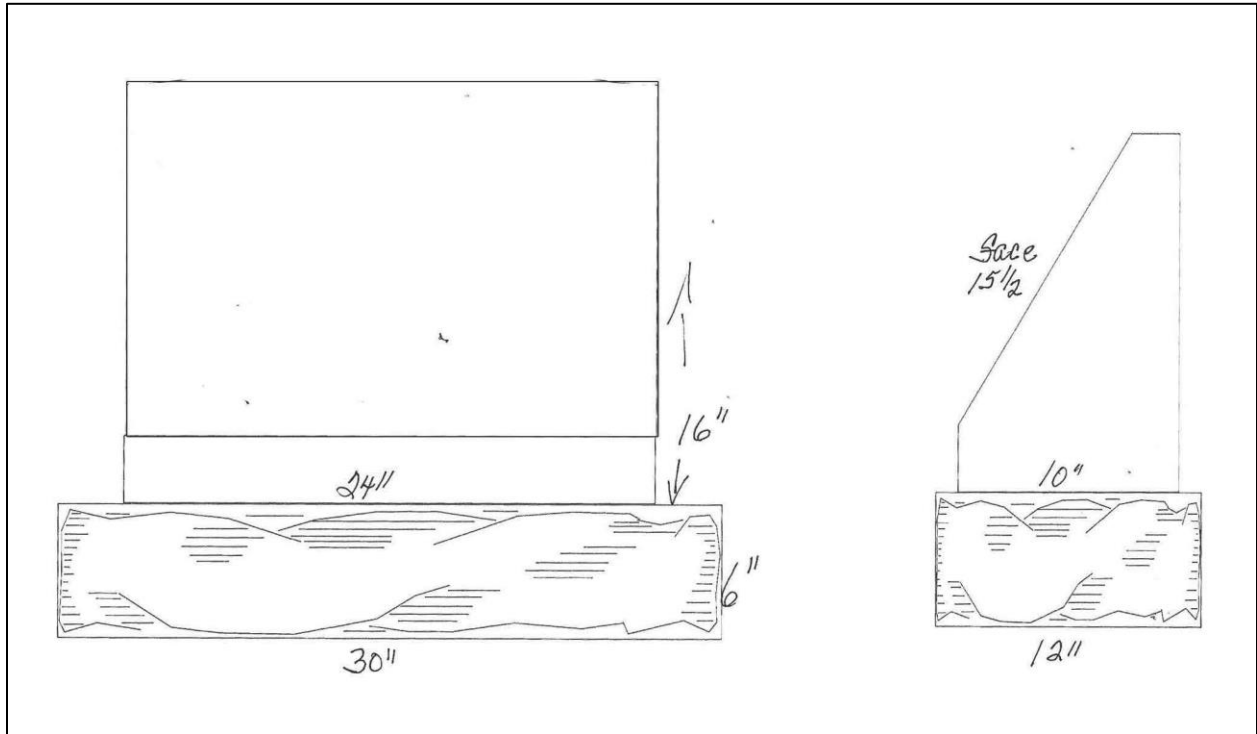

Base Dimensions: 12" by 30" wide

Total Height: 22"

Material: Grey Granite with inscription in the stone

Costs:

Estimated cost: \$1,393.15 [Exact cost to be determined when Text is finalized.]

Funding is secured in the City of Savannah's approved 2023 budget.

Funding is secured for the Escrow Payment required by the City of Savannah.

Proposed Text:

(Text inside brackets to be finalized when Savannah City Council approves name for square.)

[NEW NAME] SQUARE

LAI D OUT 1851

1851-2022 NAMED CALHOUN SQUARE IN HONOR OF JOHN C. CALHOUN

2023 NAMED IN HONOR OF [FULL NAME OF HONOREE]

Erected by the City of Savannah 2023

Text Size and Font:

Font: Times New Roman.

Title/First line: 1.8" tall

Body: 0.8" tall