

PRELIMINARY TAKE OFF CONCEPT SKETCH

SAVANNAH, GA

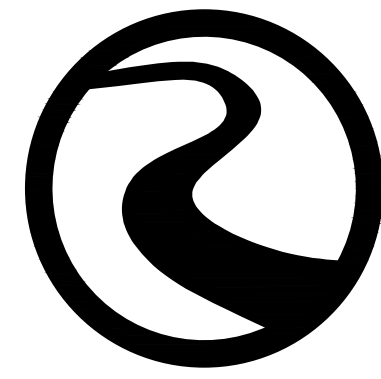

ROBERTS
CIVIL ENGINEERING

01/10/2024

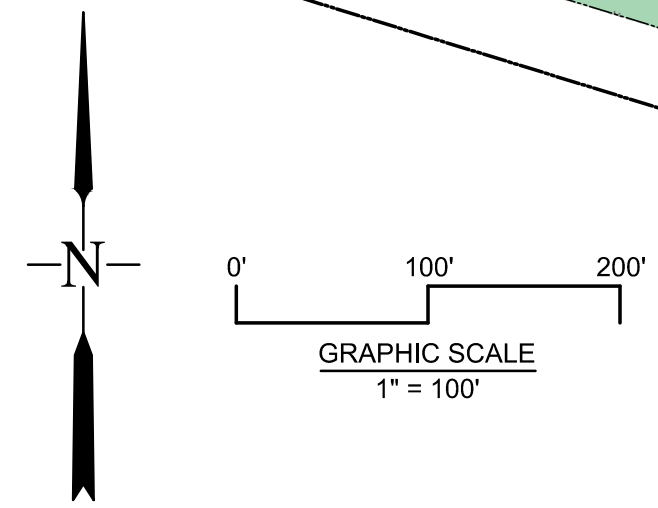
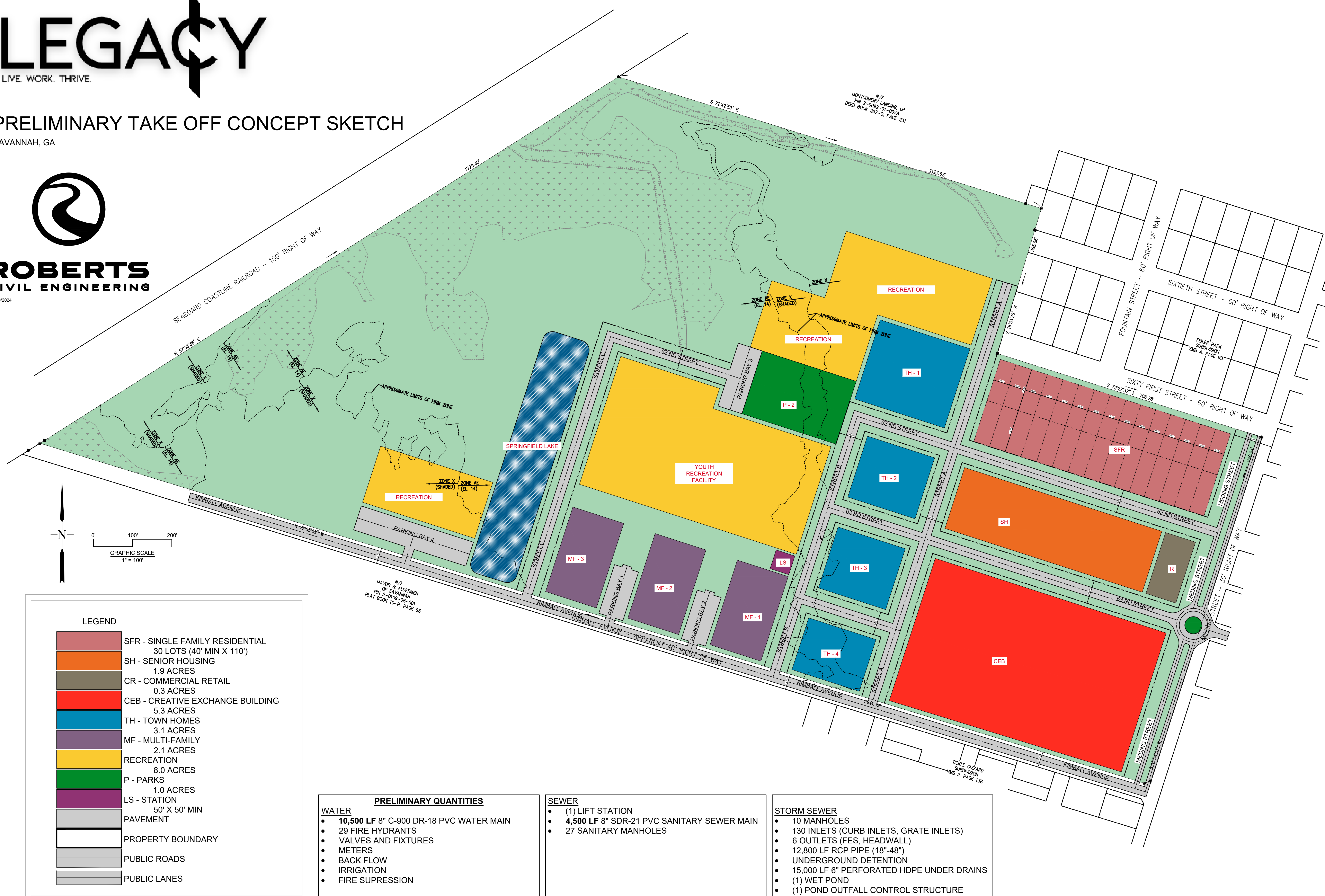

LEGEND	
[Red Box]	SFR - SINGLE FAMILY RESIDENTIAL 30 LOTS (40' MIN X 110')
[Orange Box]	SH - SENIOR HOUSING 1.9 ACRES
[Brown Box]	CR - COMMERCIAL RETAIL 0.3 ACRES
[Red Box]	CEB - CREATIVE EXCHANGE BUILDING 5.3 ACRES
[Blue Box]	TH - TOWN HOMES 3.1 ACRES
[Purple Box]	MF - MULTI-FAMILY 2.1 ACRES
[Yellow Box]	RECREATION 8.0 ACRES
[Green Box]	P - PARKS 1.0 ACRES
[Purple Box]	LS - STATION 50' X 50' MIN
[Grey Box]	PAVEMENT
[White Box]	PROPERTY BOUNDARY
[Light Grey Box]	PUBLIC ROADS
[Dark Grey Box]	PUBLIC LANES

PRELIMINARY QUANTITIES	
WATER	
•	10,500 LF 8" C-900 DR-18 PVC WATER MAIN
•	29 FIRE HYDRANTS
•	VALVES AND FIXTURES
•	METERS
•	BACK FLOW
•	IRRIGATION
•	FIRE SUPPRESSION

SEWER	
•	(1) LIFT STATION
•	4,500 LF 8" SDR-21 PVC SANITARY SEWER MAIN
•	27 SANITARY MANHOLES

STORM SEWER	
•	10 MANHOLES
•	130 INLETS (CURB INLETS, GRATE INLETS)
•	6 OUTLETS (FES, HEADWALL)
•	12,800 LF RCP PIPE (18"-48")
•	UNDERGROUND DETENTION
•	15,000 LF 6" PERFORATED HDPE UNDER DRAINS
•	(1) WET POND
•	(1) POND OUTFALL CONTROL STRUCTURE