



HISTORIC SITE AND MONUMENT COMMISSION (HSMC)

Application for Historical Markers, Monuments, and Public Art

HSMC reviews all historical markers, monuments, and public art on public property and all markers visible from the public right-of-way on private property within all local historic districts. Applications must be complete before the HSMC can begin the review process. Submit this application form and all supplemental documentation as required in the "Instructions: Submittal Criteria Checklist" with one hard copy and in PDF electronic format. Electronic files can be emailed (10mb limit) or submitted with the application on a disc.

File No.: _____ (staff only)

Applicant Contact Information:

Name: Georgia Historical Society
 Address: 104 West Gaston Street
 City: Savannah State GA Zip 31401
 Phone: 912-651-2125 ext. 119 E-Mail Address ebutler@georgiahistory.com

Property Owner Contact Information and Consent (Complete only if the marker will be on private property):

Name: _____
 Address: _____
 City: _____ State _____ Zip _____
 Phone: _____ E-Mail Address _____

Official Correspondence: Applicant Owner Other _____ (Check all that apply)

Property Information for Proposed Marker: (PIN information can be found at www.sagis.org.)

Public Property Private Property PIN (Property Identification Number): _____
 Address: _____

Scope of Work: (Check all that apply.)

HISTORICAL MARKER:	MONUMENT:
<input checked="" type="checkbox"/> Freestanding	<input type="checkbox"/> Person
<input type="checkbox"/> Wall-Mounted	<input type="checkbox"/> Place
<input type="checkbox"/> Ground-Embedded	<input type="checkbox"/> Event
<input type="checkbox"/> Other	<input type="checkbox"/> Other
PUBLIC ART (commissioned or existing work):	
<input type="checkbox"/> Mural	
<input type="checkbox"/> Sculpture	
<input type="checkbox"/> Other	

Project Description: Describe the proposed project and scope of work in detail. Additional pages may be attached. Submit all supplemental documentation as required in the separate "Instructions: Submittal Criteria Checklist."

Please see attached document

2017 Savannah-Chatham County Historic Site and Monument Commission Meeting Schedule:

Application Deadline (Due by Close of Business: 5pm)	Meeting Date
<input type="checkbox"/> December 12, 2016	January 5, 2017
<input type="checkbox"/> January 9, 2017	February 2, 2017
<input checked="" type="checkbox"/> February 6, 2017	March 2, 2017
<input type="checkbox"/> March 13, 2017	April 6, 2017
<input type="checkbox"/> April 10, 2017	May 4, 2017
<input type="checkbox"/> May 15, 2017	June 1, 2017
<input type="checkbox"/> June 12, 2017	July 6, 2017
<input type="checkbox"/> July 10, 2017	August 3, 2017
<input type="checkbox"/> August 14, 2017	September 7, 2017
<input type="checkbox"/> September 12, 2017	October 5, 2017
<input type="checkbox"/> October 16, 2017	November 2, 2017
<input type="checkbox"/> November 13, 2017	December 7, 2017

Estimated Cost of the Proposed Work: \$ 5000.00

Filing Fee Schedule:

No filing fee is required for HSMC review.

Public Notice for Historic Site and Monument Commission Meetings:

The applicant is responsible for posting the Board Meeting signs provided by the MPC fifteen (15) days prior to the HSMC Meeting. Refer to *Chapter 9 of the Markers, Monuments, and Public Art Master Plan and Guidelines for the City of Savannah* for additional posting requirements.

Signature of Legal Owner or Authorized Agent:

I have read and understand all the information enclosed in this application form. I understand that an Escrow Payment is required for any historical marker erected on public property. I hereby certify that I am the legal owner or authorized agent for the legal owner of the subject property.

Signature: 

Date: 2/6/2017

A: Project Description

The Georgia Historical Society (GHS) in partnership with First African Baptist Church (FABC) will erect a new historical marker at the site of FABC (23 Montgomery Street). The historical marker text (see Supplement E) relates the history of one of the nation's oldest continuous African-American churches. The historical marker is to be mounted on a post and installed in the sidewalk near FABC's front entry way (on Montgomery Street between W. Bryan Street and W. St. Julian Street or in the adjacent Franklin Square).

B: Photographs and Maps

Option I along Montgomery Street

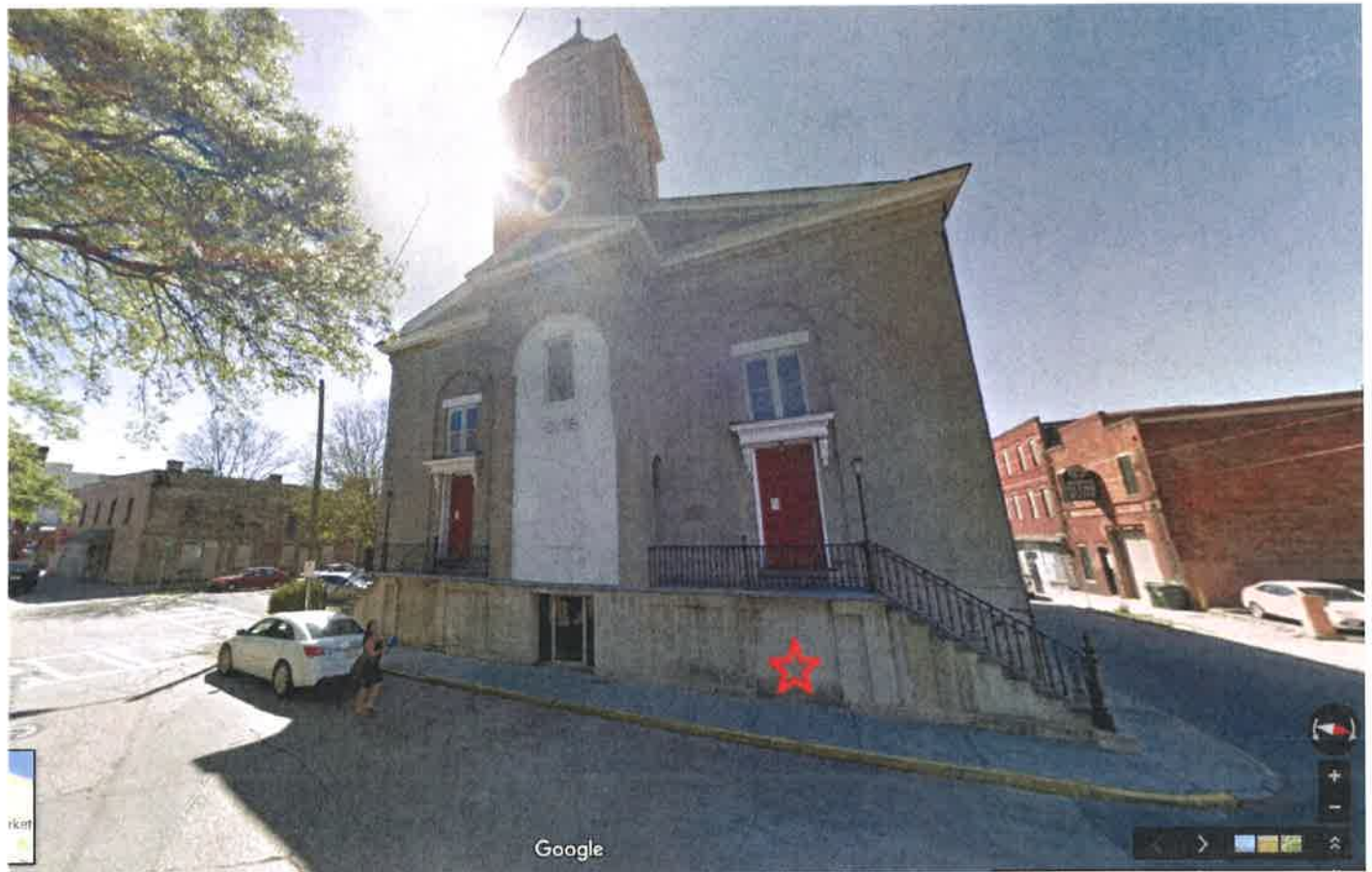

Option 2 in Franklin Square facing First African Baptist Church



W Bryan St

W Bryan St

Montgomery St



23 Montgomery Street

W Bryan St

Montgomery St

Street

W Saint Julian Street

Montgomery St

Franklin Square

Montgomery St

W Congress St

Montgomery St

Montgomery St

C: Themes

The First African Baptist Church (FABC) historical marker demonstrates the themes of “Civic and Institutional,” “Religious History,” “Local History,” and “Cultural and Ethnic Heritage.”

Civic and Institutional

The FABC historical marker demonstrates the Civic and Institutional theme through the accomplishments of the congregation in their civil rights effort, preceding and during the civil rights movement. In particular, the works of Rev. Emanuel K. Love (6th pastor) and Rev. Dr. Ralph Mark Gilbert (13th pastor) illustrate the Civic and Institutional theme. Rev. E. K. Love, an advocate for education civil rights, was instrumental in the establishment of Savannah State University, while Rev. Dr. Ralph Mark Gilbert was a key player in the revival of the Savannah chapter of the NAACP in the 1940s preceding the civil rights movement. FABC has also served as the site hosting prominent speakers, such as U.S. Representative Adam Clayton Powell and Dr. Martin Luther King, Jr.

Religious History

The theme of religious history is illustrated through the history of FABC as a religious institution. The church is considered one of the oldest continuously operating African-American churches in North America. Its roots are traced back to Rev. George Leile, who is largely referred to as the first African-American Baptist in Georgia, and the first ordained African-American preacher in the colonies.

Cultural and Ethnic Heritage

The FABC historical marker illustrates the Cultural and Ethnic Heritage theme through not only the efforts of its congregants and leadership mentioned in the above Civic and Institutional section, but also the manner and materials in which the structure was constructed. FABC was constructed by the congregants of the church with Savannah Grey brick. An architectural feature unique to Savannah, the bricks were made by the enslaved members of the congregation at nearby Hermitage Plantation.

Local History

As illustrated in the above sections, as one of the oldest continuously operating African-American churches in North America, FABC has had an impact on Savannah’s history since its origins in 1773. The congregation shaped the cultural landscape of the city, while the building itself has shaped the physical landscape with the building’s façade of Savannah Grey brick.

D: Marker Drawing

CAST ALUMINUM PLAQUE

42" W X 38-1/2" H

SCALE: 1/8" = 1"



YOU ARE THE FINAL PROOF-READER

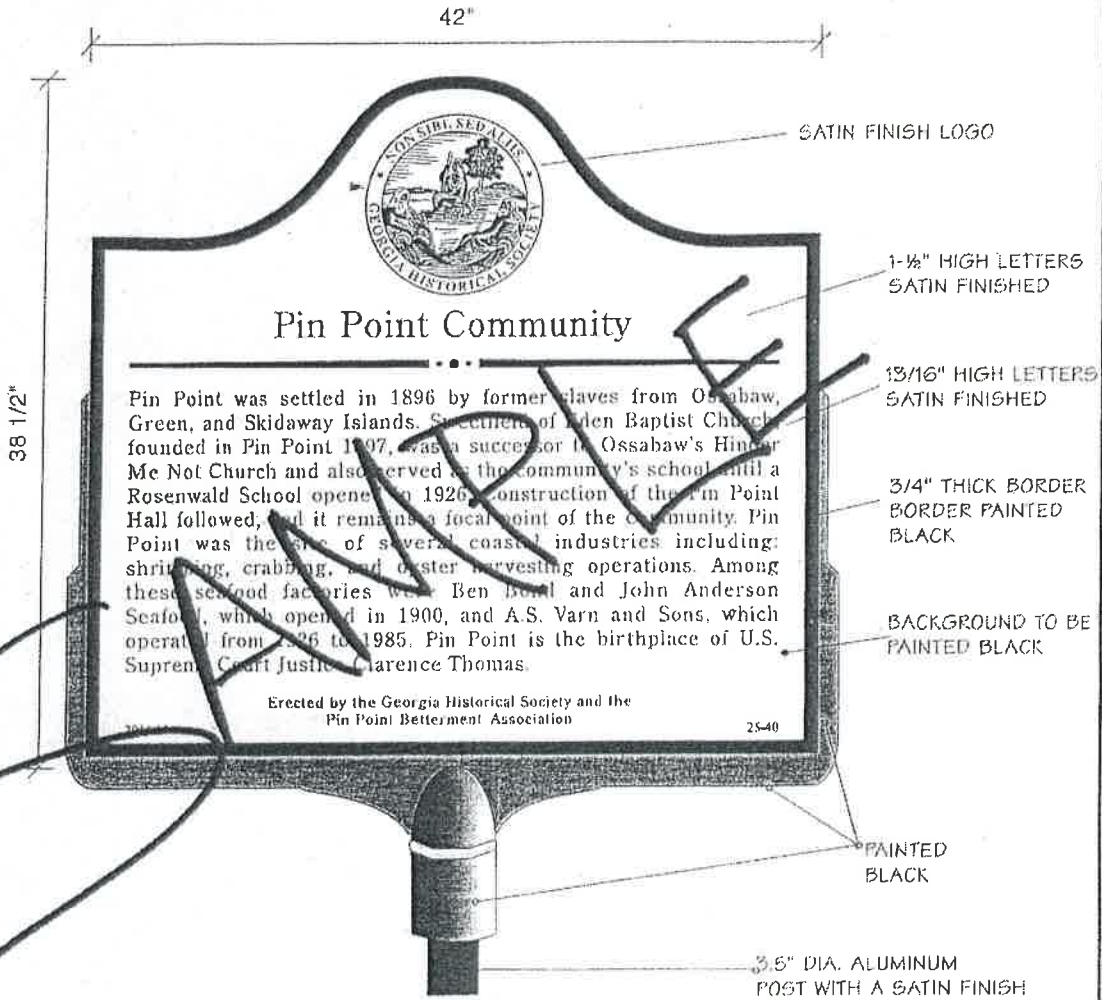

o DOUBLE SIDED MARKER

o LETTERS ARE SATIN FINISH

PATTERN COUNT:

	5/8"	1"	1 1/2"	2"
30 X 42	20 62	13 41	11 31	8 25

LETTER HEIGHT

TYPICAL COUNT

QUOTE # N/A FILE NAME: PIN POINT.CDR
 JOB # N/A DATE
 P.O. # N/A SUBMITTED: 7.29.11
 RE: PIN POINT COMMUNITY
 DRAWN BY: TONY PEREZ

PLEASE
 SPECIFY MOUNTING ATTACHMENTS

CONCEALED
 WOOD SCREWS W/ROSETTES
 EXPANSION BOLTS W/ROSETTES

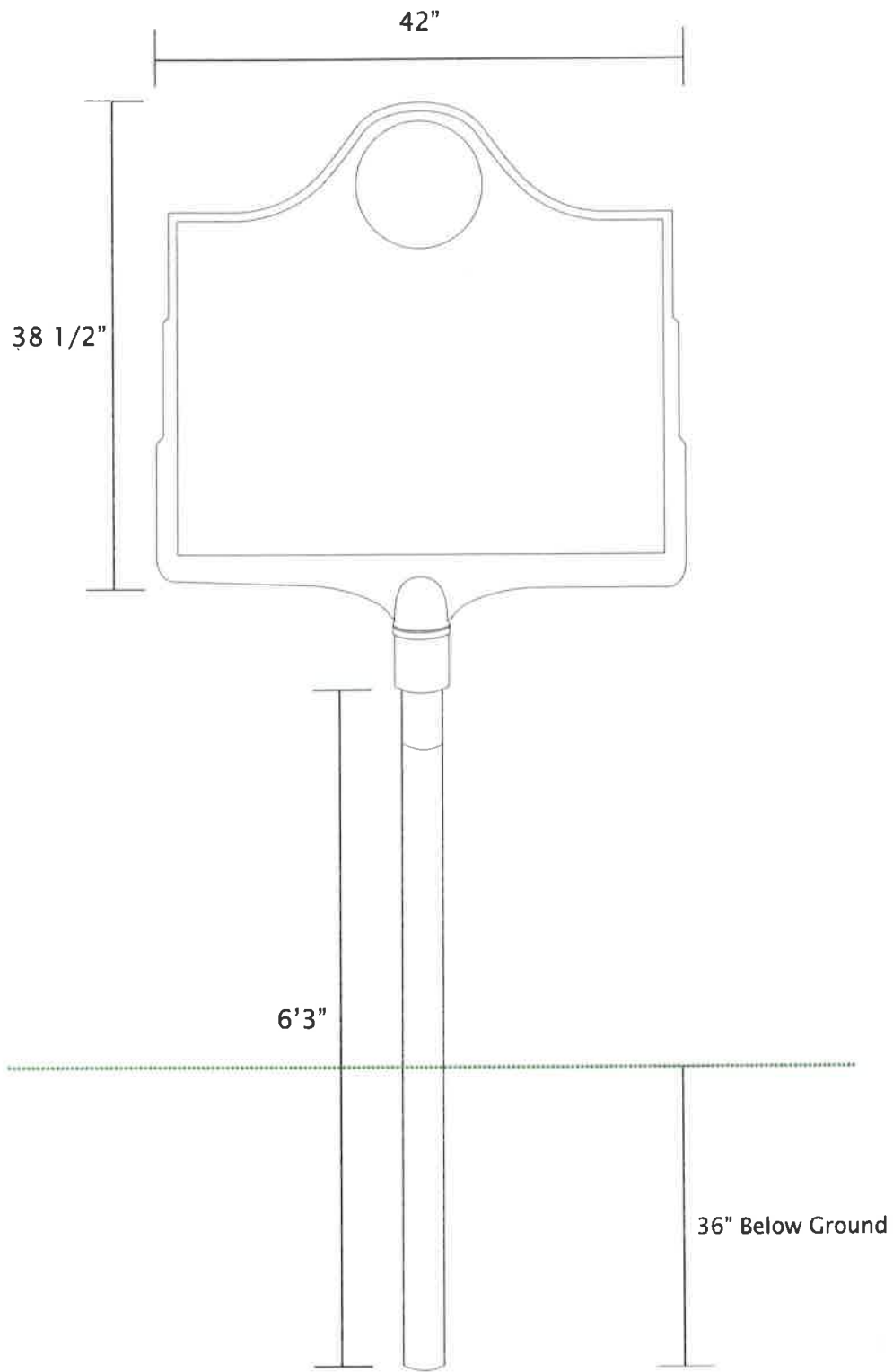

E. Historical Marker Text

First African Baptist Church

First African Baptist Church traces its roots to 1773 and the organization of a congregation at nearby Brampton Plantation by Rev. George Leile. Under the leadership of Rev. Andrew C. Marshall (3rd pastor), the congregation obtained this property. Constructed of Savannah Grey brick by congregants, both free and enslaved, the current building was completed in 1859. Rev. Emanuel K. Love (6th pastor), an advocate for African-American education and civil rights, was instrumental in establishing today's Savannah State University. Rev. Dr. Ralph Mark Gilbert (13th pastor) was a prominent leader of the NAACP and the revival of the Savannah chapter in the 1940s. U.S. Representative Adam Clayton Powell of Harlem and Dr. Martin Luther King, Jr. are among the noteworthy speakers hosted here. FABC is one of the oldest continuously operating African-American churches in North America.

Erected by the Georgia Historical Society and First African Baptist Church

F. Marker Installation

The historical marker will be installed by the City of Savannah.

G. Estimate of Costs

The estimated overall cost for a historical marker within the Georgia Historical Marker Program is \$5000.00.

H. Funds Secured

The Georgia Historical Society has secured funds of \$5000.00 for the total cost of the historical marker.

I. Escrow Payment

The Georgia Historical Society, as administrators of the Georgia Historical Marker Program along with the sponsoring organization(s) listed in the accompanying Sponsor Agreement Form, take responsibility for the repair and replacement of the submitted historical marker. We therefore ask that the Escrow Payment mentioned in the MPC Historical Marker Application be waved.

Please contact the Georgia Historical Society with any questions or concerns about the ongoing maintenance of this proposed historical marker.

J. Letter of Consent

Pending approval.