



HISTORIC SITE AND MONUMENT COMMISSION (HSMC)

Application for Historical Markers, Monuments, and Public Art

HSMC reviews all historical markers, monuments, and public art on public property and all markers visible from the public right-of-way on private property within all local historic districts. Applications must be complete before the HSMC can begin the review process. Submit this application form and all supplemental documentation as required in the "Instructions: Submittal Criteria Checklist" with one hard copy and in PDF electronic format. Electronic files can be emailed (10mb limit) or submitted with the application on a disc.

File No.: _____ (staff only)

Applicant Contact Information:

Name: Georgia Historical Society
 Address: 104 West Gaston Street
 City: Savannah State GA Zip 31401
 Phone: 912.651.2125 ext. 119 E-Mail Address ebutler@georgiahistory.com

Property Owner Contact Information and Consent (Complete only if the marker will be on private property):

Name: _____
 Address: _____
 City: _____ State _____ Zip _____
 Phone: _____ E-Mail Address _____

Official Correspondence: Applicant Owner Other _____ (Check all that apply)

Property Information for Proposed Marker: (PIN information can be found at www.sagis.org.)

Public Property Private Property PIN (Property Identification Number): _____
 Address: Guckenheimer Park

Scope of Work: (Check all that apply.)

HISTORICAL MARKER:	MONUMENT:
<input checked="" type="checkbox"/> Freestanding	<input type="checkbox"/> Person
<input type="checkbox"/> Wall-Mounted	<input type="checkbox"/> Place
<input type="checkbox"/> Ground-Embedded	<input type="checkbox"/> Event
<input type="checkbox"/> Other	<input type="checkbox"/> Other
PUBLIC ART (commissioned or existing work):	
<input type="checkbox"/> Mural	
<input type="checkbox"/> Sculpture	
<input type="checkbox"/> Other	

Project Description: Describe the proposed project and scope of work in detail. Additional pages may be attached. Submit all supplemental documentation as required in the separate "Instructions: Submittal Criteria Checklist."

Please see attached application information.

Questions: Email the Preservation Department at historic@thempc.org or call 912-651-1440.

Email, Hand Deliver or Mail Applications: MPC, Historic Preservation Department, 110 East State Street, Savannah, GA 31401

2017 Savannah-Chatham County Historic Site and Monument Commission Meeting Schedule:

Application Deadline (Due by Close of Business: 5pm)	Meeting Date
<input type="checkbox"/> December 12, 2016	January 5, 2017
<input type="checkbox"/> January 9, 2017	February 2, 2017
<input type="checkbox"/> February 6, 2017	March 2, 2017
<input type="checkbox"/> March 13, 2017	April 6, 2017
<input checked="" type="checkbox"/> April 10, 2017	May 4, 2017
<input type="checkbox"/> May 15, 2017	June 1, 2017
<input type="checkbox"/> June 12, 2017	July 6, 2017
<input type="checkbox"/> July 10, 2017	August 3, 2017
<input type="checkbox"/> August 14, 2017	September 7, 2017
<input type="checkbox"/> September 12, 2017	October 5, 2017
<input type="checkbox"/> October 16, 2017	November 2, 2017
<input type="checkbox"/> November 13, 2017	December 7, 2017

Estimated Cost of the Proposed Work: \$ 5000.00

Filing Fee Schedule:

No filing fee is required for HSMC review.

Public Notice for Historic Site and Monument Commission Meetings:

The applicant is responsible for posting the Board Meeting signs provided by the MPC fifteen (15) days prior to the HSMC Meeting. Refer to *Chapter 9 of the Markers, Monuments, and Public Art Master Plan and Guidelines for the City of Savannah* for additional posting requirements.

Signature of Legal Owner or Authorized Agent:

I have read and understand all the information enclosed in this application form. I understand that an Escrow Payment is required for any historical marker erected on public property. I hereby certify that I am the legal owner or authorized agent for the legal owner of the subject property.

Signature: 

Date: 4/7/17

Questions: Email the Preservation Department at historic@thempc.org or call 912-651-1440.

Email, Hand Deliver or Mail Applications: MPC, Historic Preservation Department, 110 East State Street, Savannah, GA 31401

A: Project Description

The Georgia Historical Society (GHS) in partnership with the Waters Foundation and Hunter Maclean will erect a new historical marker on Mayor Malcolm Maclean. The historical marker text (see Supplement E) relates the history of Maclean's accomplishments as Mayor. The historical marker is to be mounted on a post and installed in Guckenheimer Park near the residence of Mayor Maclean on 45th Street.

C: Themes

The Malcolm Maclean historical marker demonstrates the themes of “Civic and Institutional,” “Social and Humanitarian,” “Industry and Commerce,” and “Military History.”

Civic and Institutional

The Malcolm Maclean historical marker demonstrates the Civic and Institutional theme through the accomplishments of Mayor Maclean. Maclean was a member of the Savannah Citizens Committee, served three years as an assistant city attorney, and in 1957 became an alderman. When Mayor Lee Mingledorff resigned, on July 29, 1960, he selected Maclean to succeed him. Maclean served until the Fall of 1966, losing a run for reelection to J. C. Lewis. Maclean supported ‘economic development and urban renewal’ and spoke of the development of an \$11.1 million plant to combat Savannah’s water pollution. Mayor Maclean was also instrumental in the establishment of Memorial Health hospital and bringing Gulfstream Aerospace to Chatham County.

Social and Humanitarian

The historical marker illustrates the Social and Humanitarian theme through the discussion of Maclean’s largely non-violent desegregation and integration of Savannah during the summer of 1963. Maclean worked with members of the NAACP’s Legal Counsel, such as W. W. Law and Eugene Gadson, to implement non-violent desegregation strategies. Mayor Maclean’s tenure oversaw the desegregation of public libraries, city restrooms, and store lunch counters, as well as the removal of segregation signs.

Industry and Commerce

Maclean was a proponent of increased tourism, the building of a riverfront auditorium and a convention center complex, the expanding of library facilities, and the remodeling of police headquarters—initiatives that would eventually be implemented in Savannah after Maclean’s service as mayor. Maclean is also credited with having a role in bringing Gulfstream to Savannah and helping start Memorial Health.

Military History

Maclean served in the US Navy as commanding officer of the USS *Edsall* in World War II, and, during the latter part of the war, as commanding officer of the USS *Frankovich*. He was awarded a Bronze Star after rescuing the crew of a burning tanker during his time as commanding officer of the USS *Edsall*. Maclean also served under the rank of Commander during the Korean War for two years, marking the end of his military career.

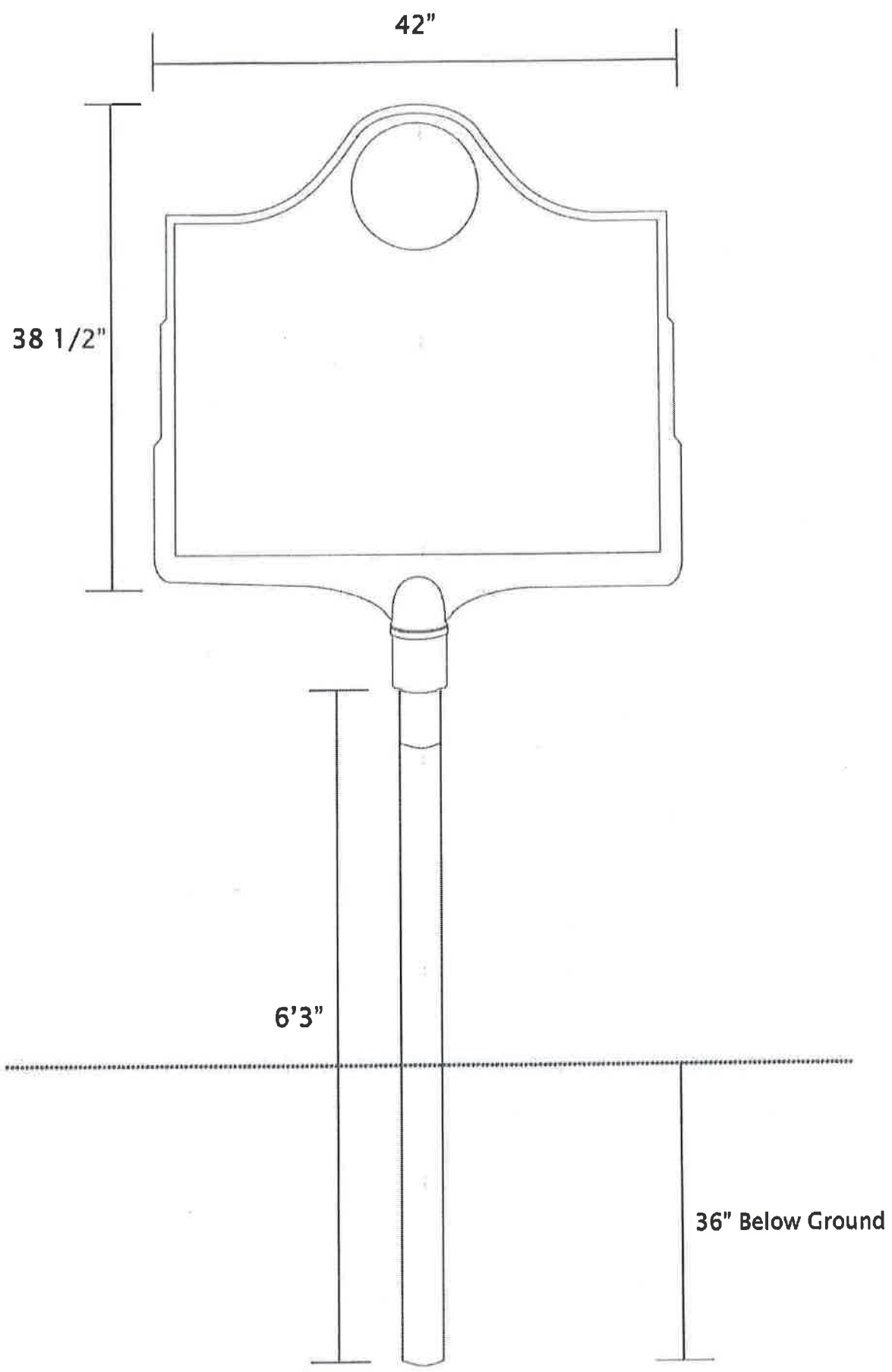

CAST ALUMINUM PLAQUE

42" W x 38-1/2" H

SCALE: 1/8" = 1"



YOU ARE THE FINAL PROOF-READER

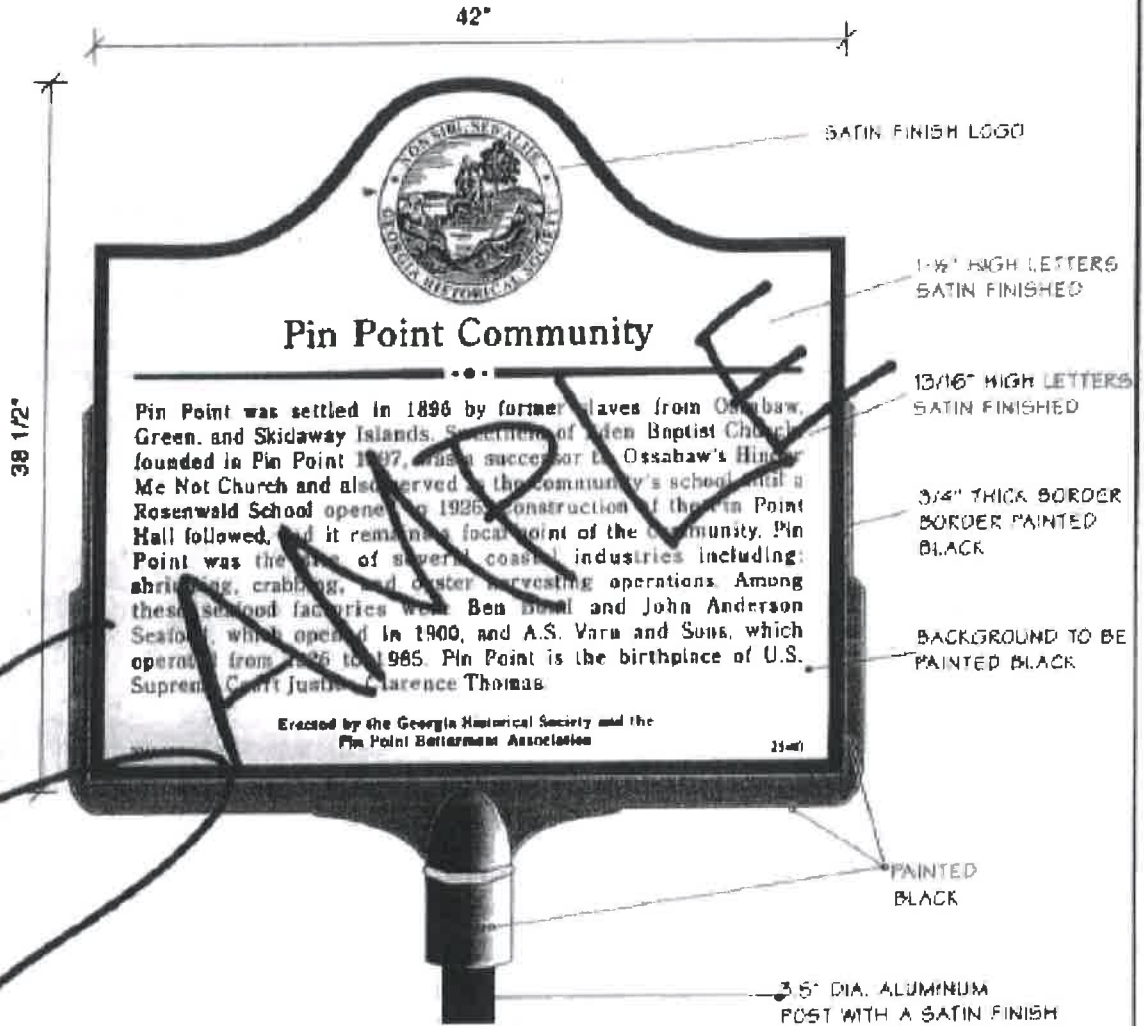

○ DOUBLE SIDED MARKER

○ LETTERS ARE SATIN FINISH

PATTERN COUNT:

5/8"		1"		1 1/2"		2"	
20	62	15	41	11	31	8	25

LETTER HEIGHT

TYPICAL COUNT

ALUM UNF ALUM UNF ALUM UNF ALUM UNF

E. Historical Marker Text

Malcolm R. Maclean (1919-2001)

Malcolm R. Maclean served in the U.S. Navy during World War II and the Korean War, rising to the rank of commander. After Harvard Law, Maclean entered Savannah politics. His fellow aldermen selected Maclean as mayor in 1960 to fill an unexpired term. Elected with bi-racial support in 1962, Maclean sought to avoid the violence surrounding the Civil Rights movement that occurred elsewhere and responded with moderation to protests and a boycott of segregated businesses. Maclean negotiated with business and civil rights leaders, including W. W. Law and Eugene Gadsden, to accomplish the largely peaceful desegregation of Savannah before the Civil Rights Act of 1964. Voters rejected Maclean's reelection bid in 1966. Maclean also helped establish Memorial Health hospital and recruit Gulfstream Aerospace. Maclean lived nearby on E. 45th Street and is buried in Bonaventure Cemetery.

Erected by the Georgia Historical Society, Waters Foundation, and Hunter Maclean

F. Marker Installation

The historical marker will be installed by the City of Savannah.

G. Estimate of Costs

The estimated overall cost for a historical marker within the Georgia Historical Marker Program is \$5000.00.

H. Funds Secured

The Georgia Historical Society has secured funds of \$5000.00 for the total cost of the historical marker.

I. Escrow Payment

The Georgia Historical Society, as administrators of the Georgia Historical Marker Program along with the sponsoring organization(s) listed in the accompanying Sponsor Agreement Form, take responsibility for the repair and replacement of the submitted historical marker. We therefore ask that the Escrow Payment mentioned in the MPC Historical Marker Application be waved.

Please contact the Georgia Historical Society with any questions or concerns about the ongoing maintenance of this proposed historical marker.

J. Letter of Consent

Pending approval.